



**Lithoss**<sup>®</sup>  
Magazine

© 2015 Lithoss Designed Switches - Editie 09/2015 NL

**Lithoss Keychain**  
*we found the key*

03 Introduction

---

04 Spotlight on Project:  
Textured Black in private residence

---

05 New product:  
round power outlet Void

---

06 New product:  
Lithoss USB charger

---

08 New finish: CU29

---

10 PIANO 2015

---

12 New finish: Tin antique

---

14 Spotlight on Project:  
Hotel La Réserve

---

16 New finish: Brass antique

---

18 Spotlight on Project:  
private residence Sofie & Tom

---

20 (Re)new(ed) finish: Bronze antique

---

22 R&D news: CATIA

---

23 New product:  
Keychain

---

24 Coming soon... Cockpit

---



04 Spotlight on Project: Textured Black in private residence



16 New finish: Brass antique



18 Spotlight on Project:  
private residence Sofie & Tom



If we look back on the beginning of 2015, you will no doubt recall our mailing “we found the key”. This was the kick-off for a promising campaign year during which Lithoss would try to win you over with their stylish finishes and innovative collections. We can assure you that we have been very busy this past year and you will be able to see the results of our hard work at the Maison&Object exhibition, which is scheduled to take place in Paris from September 4 to September 8. During this design exhibition, we will proudly be presenting the long-awaited introduction of our “cockpit” collection. You can see all the innovations described in this magazine at the exhibition. We kindly invite you to pay us a visit.

We have also thoroughly renewed our website bringing it entirely up to date. We kindly invite you to visit our website at [www.lithoss.com](http://www.lithoss.com) to check out our new product photos showcasing the beautiful, unique Lithoss finishes.

# *Introduction*

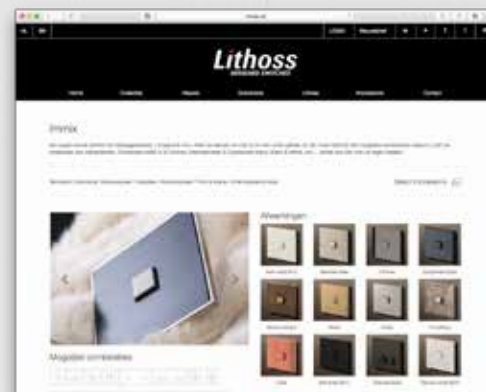
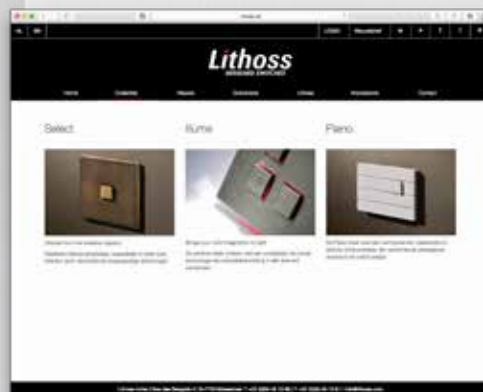

[www.lithoss.com](http://www.lithoss.com)

*Project: Textured Block in private residence*



## *New product - VOID round power outlet*

An absolute showstopper in the making is the void, our latest series of round power outlets. The power outlet is discretely hidden behind the cover plate, giving your power outlet that perfect sleek appearance you're looking for. With this specific product range, you will be able to enjoy the beautiful Lithoss finishes even more. Enjoy the photos and let yourself be seduced.



## *New product: Lithoss USB charger*



We are proud to present our latest product release: the Lithoss USB charger. This charger's design is a perfect example of the Lithoss philosophy for design since it's not only beautiful, but also very fast. By the way: did you know that it charges most devices quicker than the standard adapters supplied by the manufacturers?! The Lithoss USB charger can easily be used on every standard (European) mounting box that connects directly to 230V.

Moreover, the Lithoss USB charger has an indication LED light so that you will always be able to see how much it has charged. It goes without saying that all possible safety provisions (short-circuit, heat, reversed polarity,...) are in place allowing you to charge your device not only safely but also in style.

### Specifications:

230V connection

2A - 10W (5V DC)

Indication LED light (charge - trickle charge - fully charged)

Ref. Sn0106



Ref. Sn0117



*charging...*

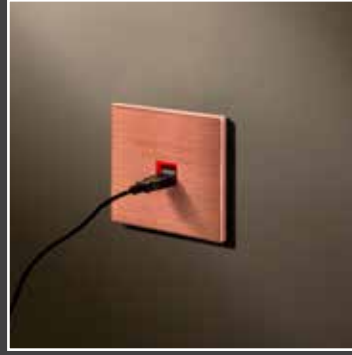

*100% charged*

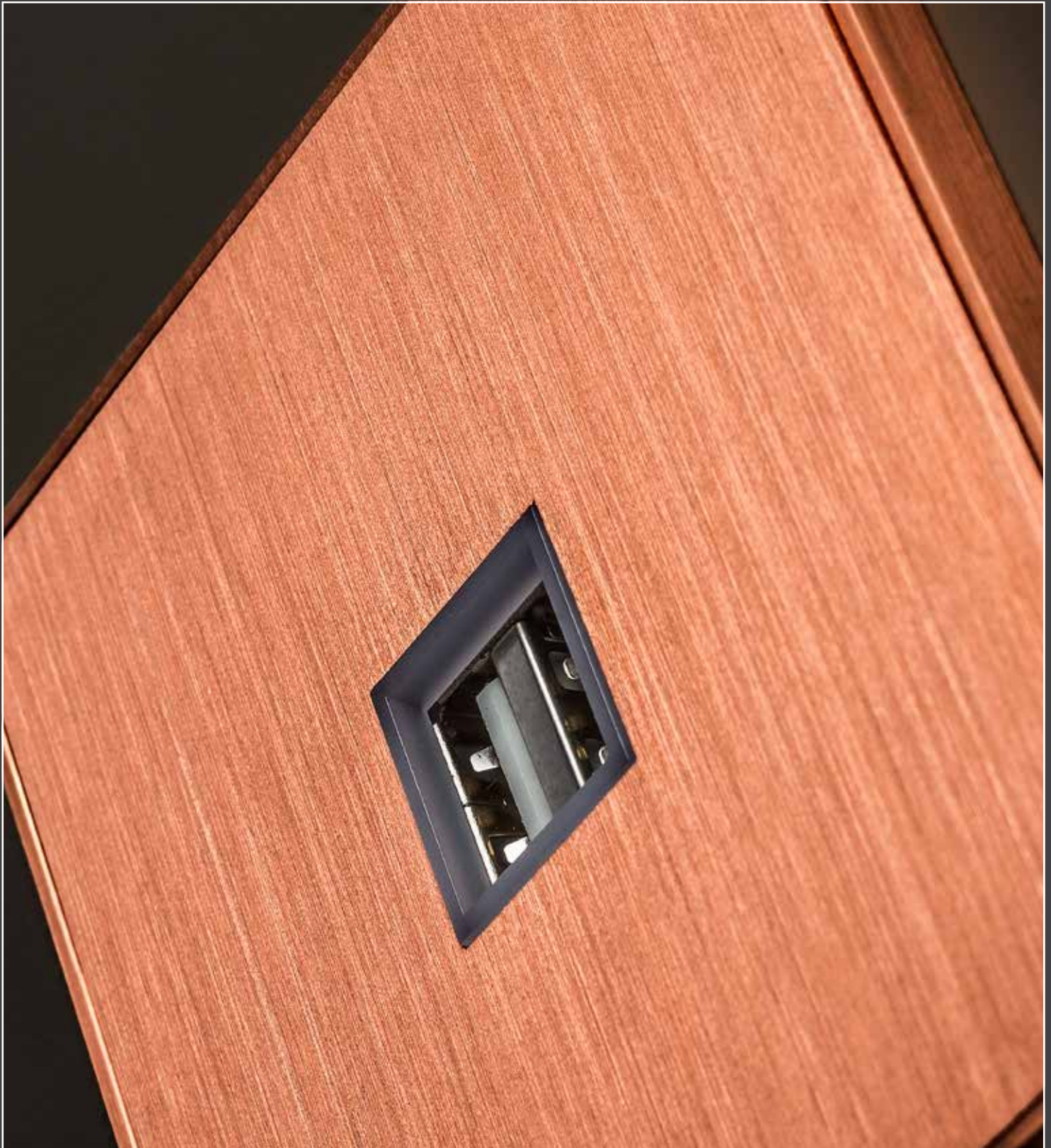

## New finish: *CU<sub>29</sub>*

You already had the chance to see our new stylish collection Cu29 (matt red copper) at ISE Amsterdam. Copper (chemical element Cu and atomic number 29) is a precious metal, which in the mythology is often associated with the goddess Aphrodite because of its beautiful shiny features. Lithoss finely brushes the copper and adds a brilliant varnish to achieve a luxurious finish.

Cu29 is an elegant collection entirely in keeping with the sleek Lithoss design that will certainly appeal to architects thanks to the various combinations that can be made with our standard finishes such as Cu29 & Textured Black, for instance. The beautiful copper is available on all items in the Lithoss series: domotics (optional feed back LED), KNX (optional feedback LED & temperature sensor) and 250V push buttons. 1-4 buttons on one plate, 2-8 buttons on a double plate and up to 12 buttons on a triple plate.



1T



VO1V



2TMGR



# Cu29

by Lithoss®

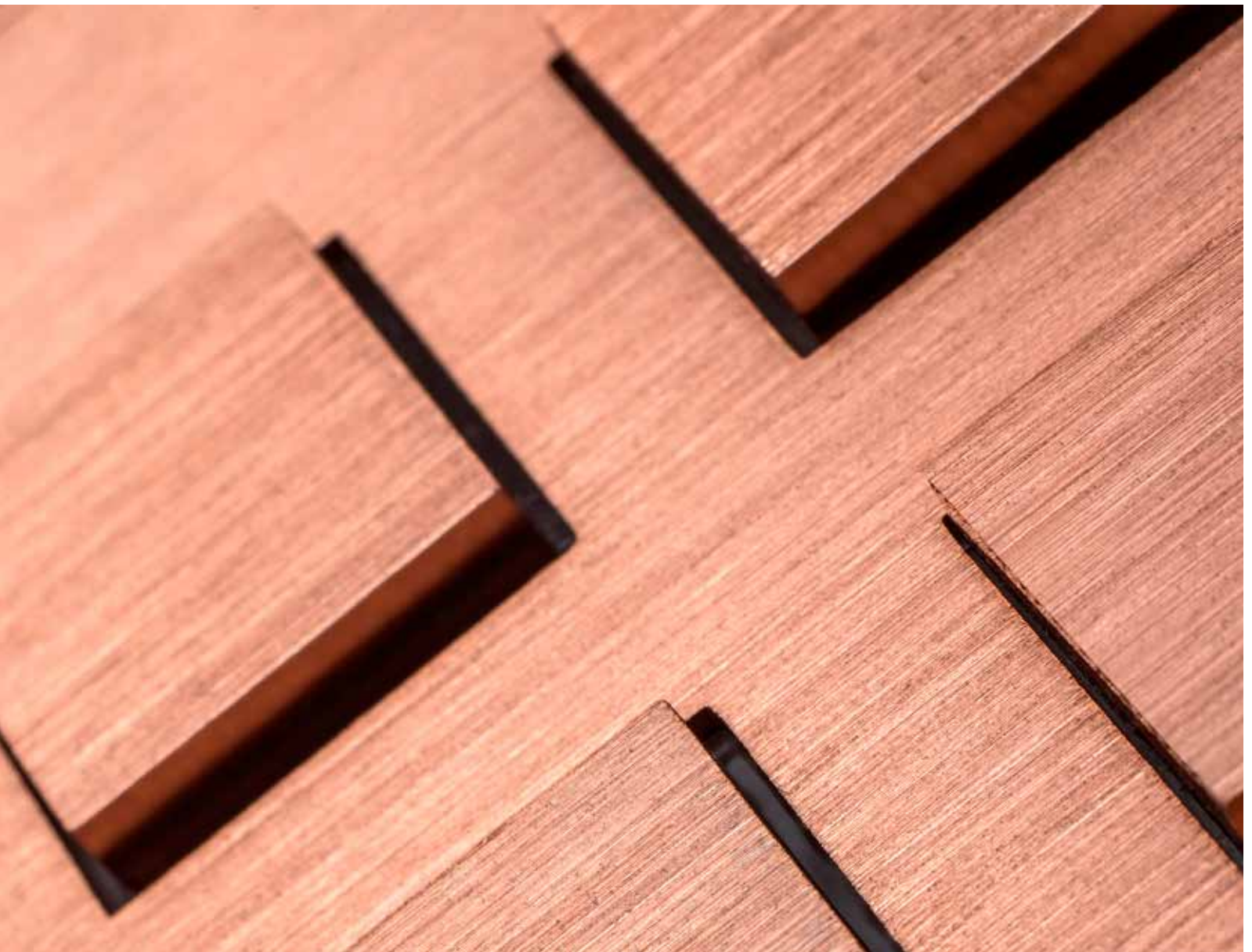

## Piano 2015

*Piano, which was awarded the Henry Van De Velde Label only last year, has been slightly transformed in 2015. The available colours have been limited to white (RAL9010) and black (RAL9011), making the Piano even more Piano. Some of the previous finishes are no longer available as standard. Nevertheless, Piano can still be personalised in a RAL colour of your choice.*

*Below you will find an update of the current product range.*



1P

24/250V KNX Pi1P128  
Pi1P828



2P

24/250V KNX Pi2P128  
Pi2P828



3P

24/250V KNX Pi3P128  
Pi3P828

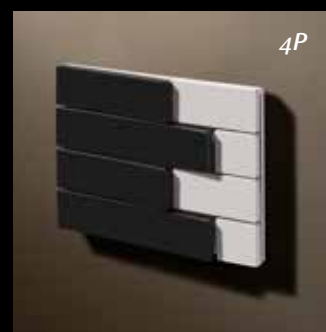

4P

24/250V KNX Pi4P128  
Pi4P828



MG (\*)

24/250V KNX PiMG502  
PiMG602



2T

24/250V KNX Pi2T128  
Pi2T828



3T

24/250V KNX Pi3T128  
Pi3T828

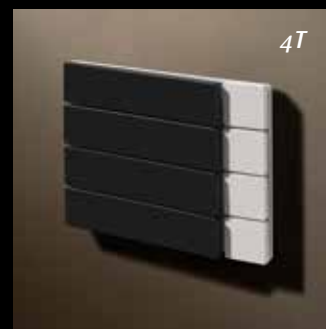

4T

24/250V KNX Pi4T128  
Pi4T828



1P

24/250V  
KNX Pi1P102  
Pi1P802



2P

24/250V  
KNX Pi2P102  
Pi2P802



3P

24/250V  
KNX Pi3P102  
Pi3P802



4P

24/250V  
KNX Pi4P102  
Pi4P802



MG (\*)

24/250V  
KNX PiMG502  
PiMG602



2T

24/250V  
KNX Pi2T102  
Pi2T802



3T

24/250V  
KNX Pi3T102  
Pi3T802

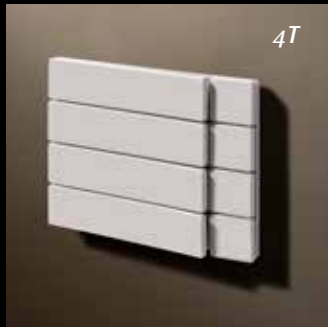

4T

24/250V  
KNX Pi4T102  
Pi4T802



XT

Pi0P002



1P

24/250V  
KNX Pi1P118  
Pi1P118



2P

24/250V  
KNX Pi2P118  
Pi2P818



3P

24/250V  
KNX Pi3P118  
Pi3P818



4P

24/250V  
KNX Pi4P118  
Pi4P818



MG (\*)

24/250V  
KNX PiMG518  
PiMG618



2T

24/250V  
KNX Pi2T118  
Pi2T818



3T

24/250V  
KNX Pi3T118  
Pi3T818



4T

24/250V  
KNX Pi4T118  
Pi4T818



XT

Pi0P018

## *New finish: TIN*

Lithoss has added yet another finish to its already extensive portfolio - Tin. Now this latest finish has already become many people's new favourite.

Tin is a handmade finish achieved by applying a light structure to a coarse brass plate, which is then galvanised with nickel. This specific look is created by applying a special finishing layer in 'gunpowder black'.

Better yet, this finish works brilliantly in both a classic and a contemporary interior.



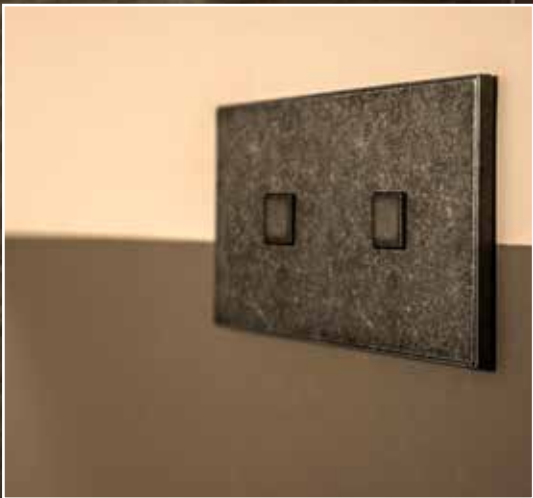
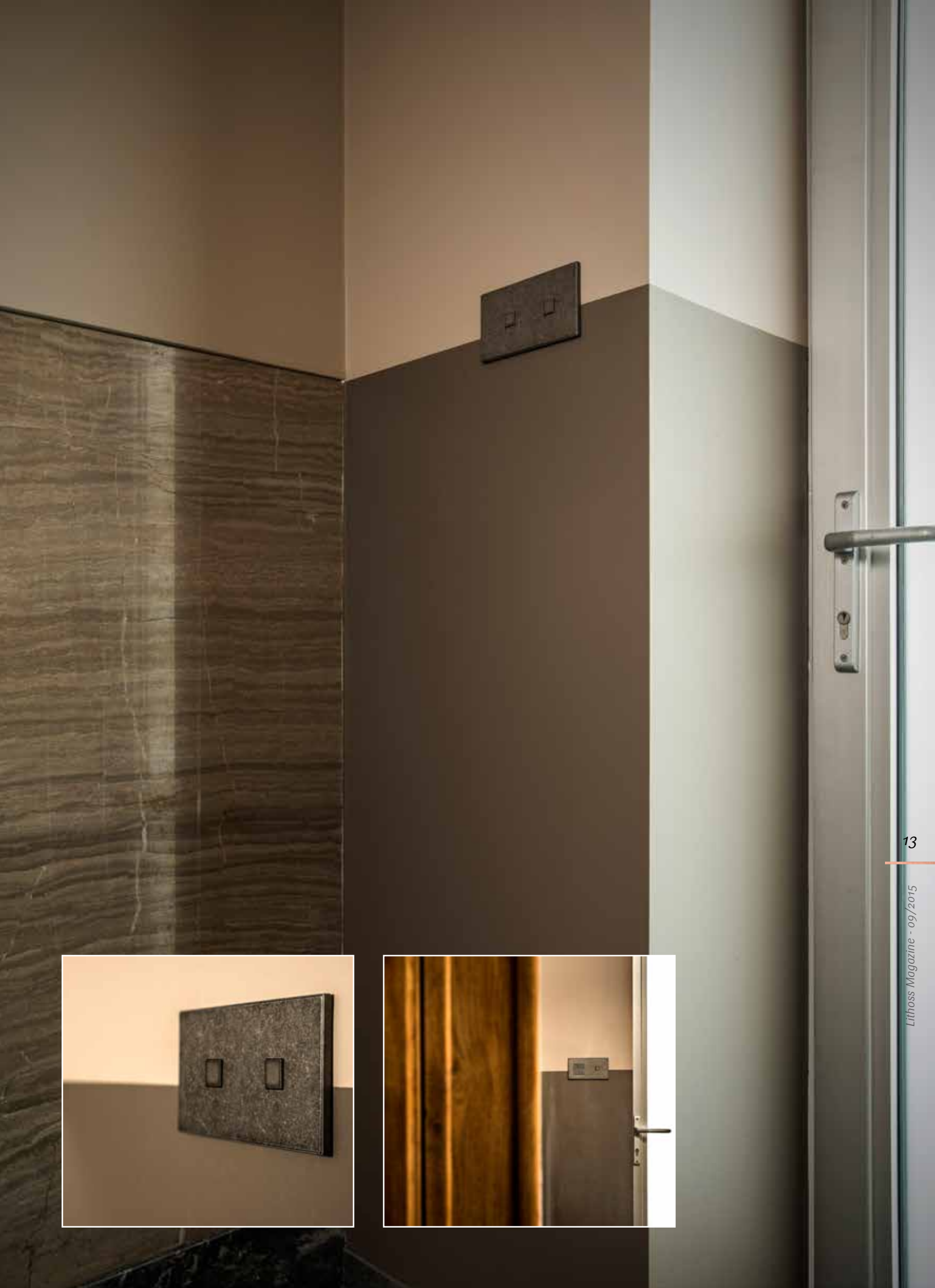

## Spotlight on project: Hotel La Réserve (Knokke-Heist, België)

In our last magazine you could read the interview with Mrs. Van Thillo in which she speaks about her many years of experience in the hospitality industry, about her specific search for Belgian design and how Lithoss was the perfect match for her La Réserve theme. Now a professional photographer has captured everything on camera and it goes without saying that we are very pleased to be able to share these photos with you.

More info: [www.la-reserve.be](http://www.la-reserve.be)





## *New finish: Brass antique*

After the introduction of our Tin antique collection proved to be such a tremendous success, we decided to analyse our current finishes and came to the conclusion that our classic Brass finish would be perfect for creating another version with that same antique look.

Brass antique is in perfect harmony with a classic interior since the switches look great next to a beautiful piece of antique, a baroque painting, etc.

Thanks to this finish created by Lithoss, you now will be able to add that one perfect detail to your interior to create the perfect look. You can transform your interior entirely and turn it into a lovely and pleasant place to be.

Just like Tin and Bronze antique this finish is entirely handmade in Belgium! Handmade in Belgium!







## *Spotlight on Project: private residence Sofie & Tom*

Sofie and Tom have turned their home into a truly warm retreat by using Lithoss, among other things. These project photos clearly demonstrate how our new product range void in Cu29 fits perfectly in their modern interior and how a Lithoss USB charger is an example of pure class on their desk.





## *(Re)new(ed) finish: Bronze antique*

For years, bronze has been a frontrunner in our product range and now, with the Bronze antique finish, it is bound to become even more popular. The structure of this renewed finish has more depth, which really brings it to life. This finish is exciting under all circumstances and will certainly be an added value in the right interior.

You really should see it for yourself.





V01117



S01117

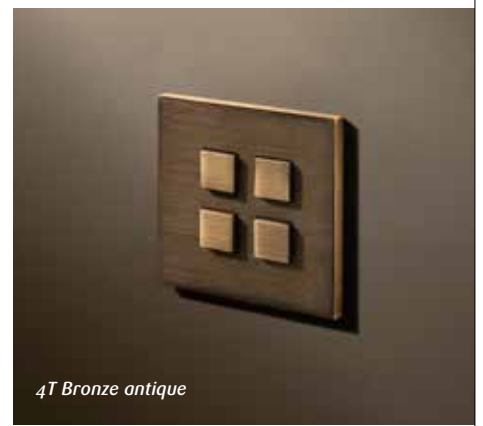

4T Bronze antique



SB1TMG



## R&D news: CATIA

In order to be able to develop all the new Lithoss products, we need a sound and professional CAD system. Therefore, we searched for a new CAD system and ultimately opted for CATIA by Dassault systems. This system is truly the best of the best in the field of design and development of new devices. Thanks to this fully parametric 3D CAD package, our R&D department is able to work quicker, better and smarter.

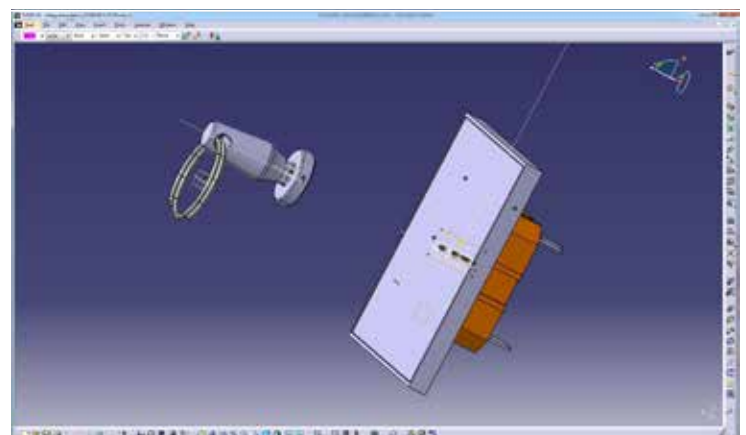
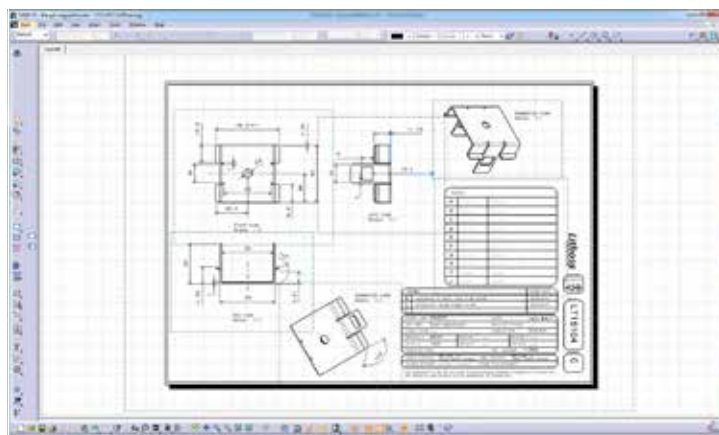
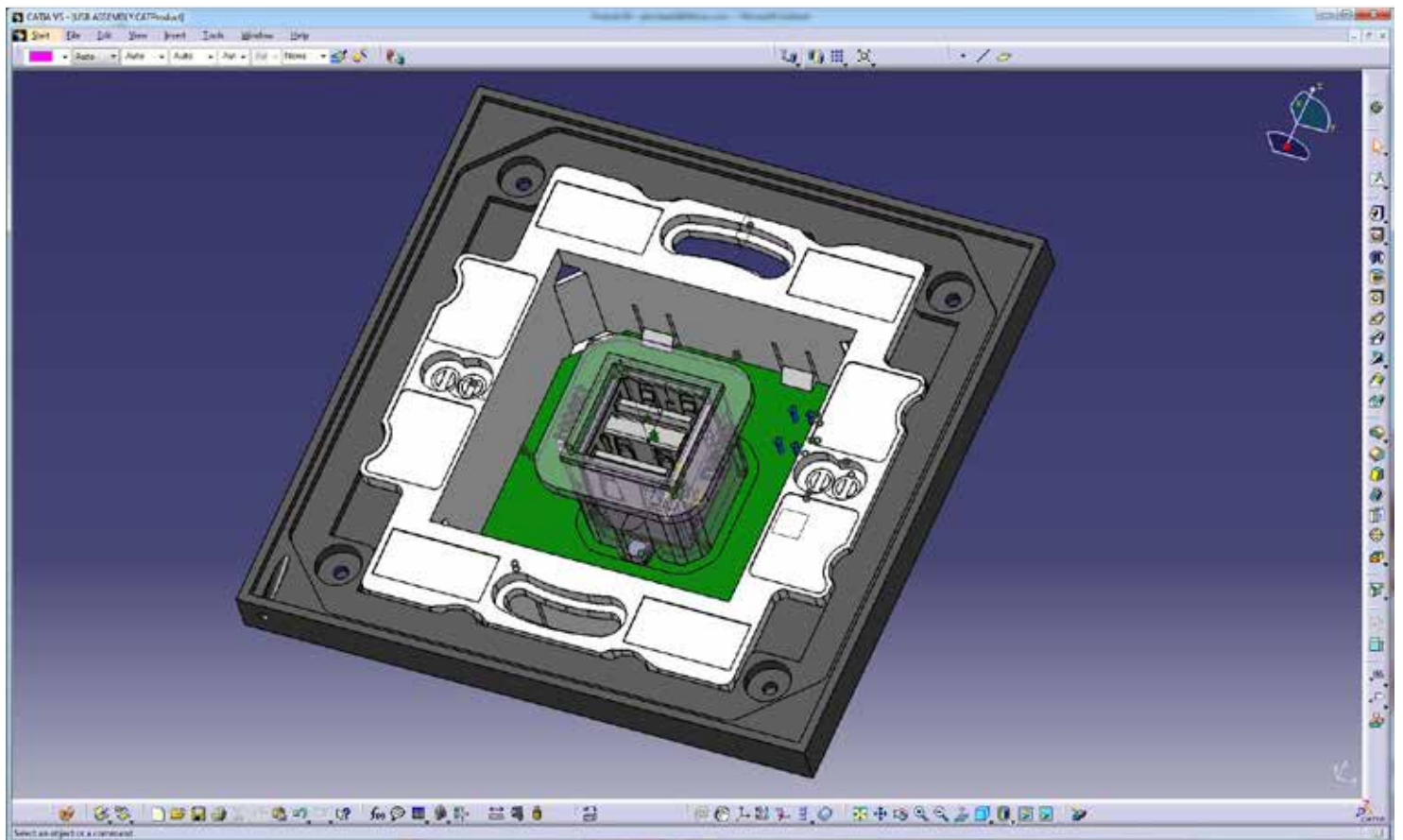

## *New product: Keychain*



“SUPERNOVA”,

This is a range with which Lithoss wants to expand the switch part and meet your needs in contemporary technology / design / lifestyle / ... This new series is a perfect reflection of the typical Lithoss DNA and is a perfect example of the Lithoss design philosophy.

In addition to the USB charger, we have now designed the next ‘supernova’: the Lithoss keychain. This product has been created by attaching a Lithoss cover plate onto a standard mounting box with an extremely strong magnet inside. With each device you will receive two keychains that you can attach to the cover plate. Now you will have a permanent place to leave your keys and not only that, it will be in style. Hang this supernova at the same height as the switches to create a harmonious style.



## Coming Soon... Cockpit

Sneak preview of our new series of mechanical switches Cockpit, which will be presented at Maison & Object (Paris) and A. Track (Antwerp).

Available soon.



1-3-4 oktober 2015



4-8 september 2015



Lithoss - designed switches  
Rue de Bengalis 4  
B - 7700 Mouscron

T +32 (0)56 48 15 70  
F +32 (0)56 48 15 91

info@lithoss.com  
www.lithoss.com

All data are in good faith and reflect our current knowledge; hence this can not be used against us.  
The registered marks and all other rights, included pictures, are property of Lithoss. All rights reserved.